

Autodesk®
Moldflow® Adviser

Design plastics confidently.

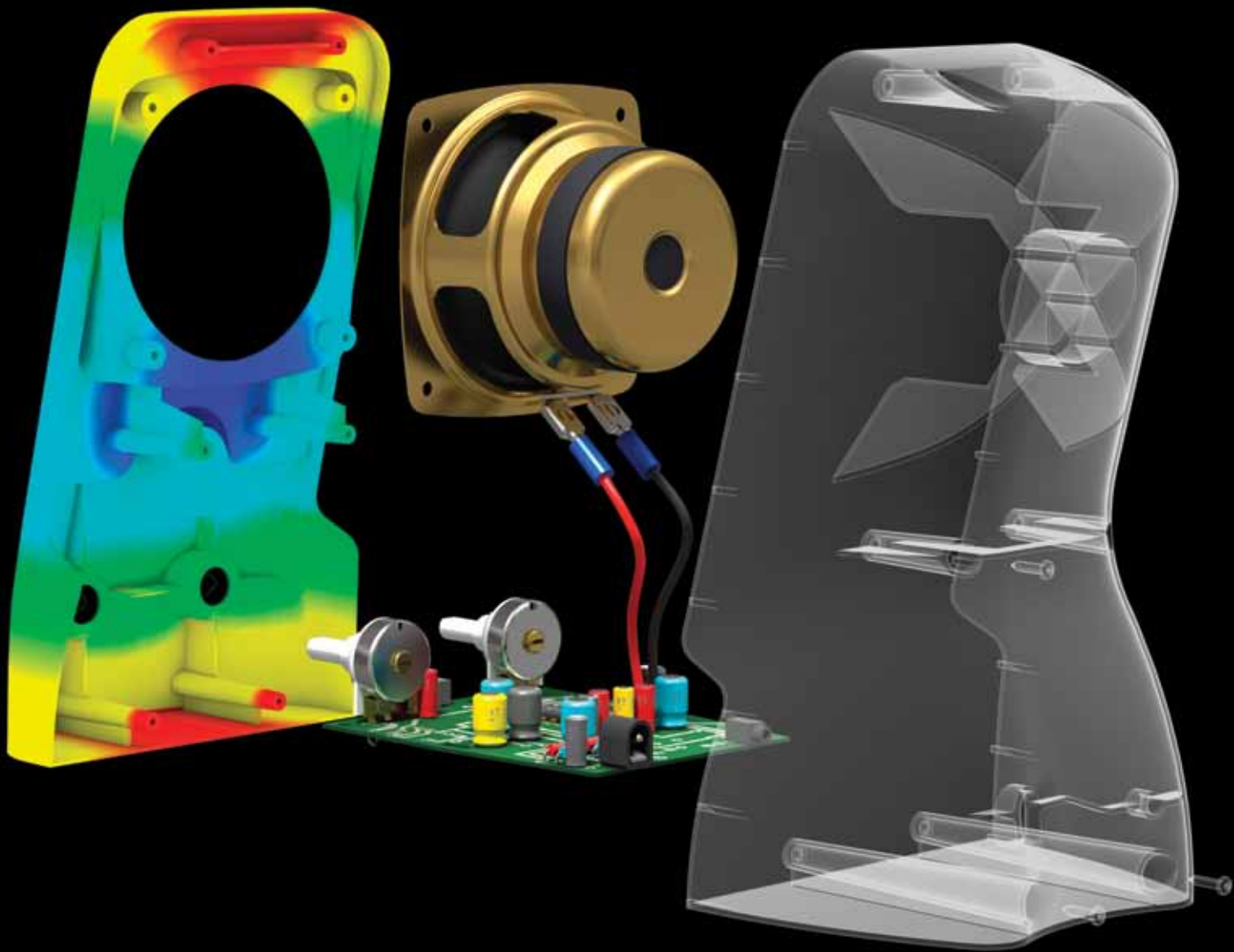

Design Plastic Parts and Injection Molds with Confidence

Discover, communicate, and resolve potential manufacturing defects earlier in the product development cycle with Autodesk Moldflow Adviser software.

Contents

Design Plastic Parts and Injection Molds with Confidence	1
Simulation.....	2
CAD Interoperability and Meshing	4
Results Evaluation and Productivity Tools.....	5

Autodesk® Moldflow® Adviser injection molding simulation software, part of the Autodesk® solution for Digital Prototyping, provides wizard-based tools to help validate and optimize plastic part, injection mold, and tool designs before manufacturing begins. Using a digital prototype to simulate the plastic injection molding process helps reduce the number of costly physical prototypes required to design plastic parts and helps get innovative products to market faster and with greater confidence.

Autodesk Moldflow Adviser Product Line

Autodesk is dedicated to providing a wide range of injection molding simulation tools to help designers, mold makers, and engineers create more accurate digital prototypes and bring better products to market at less cost.

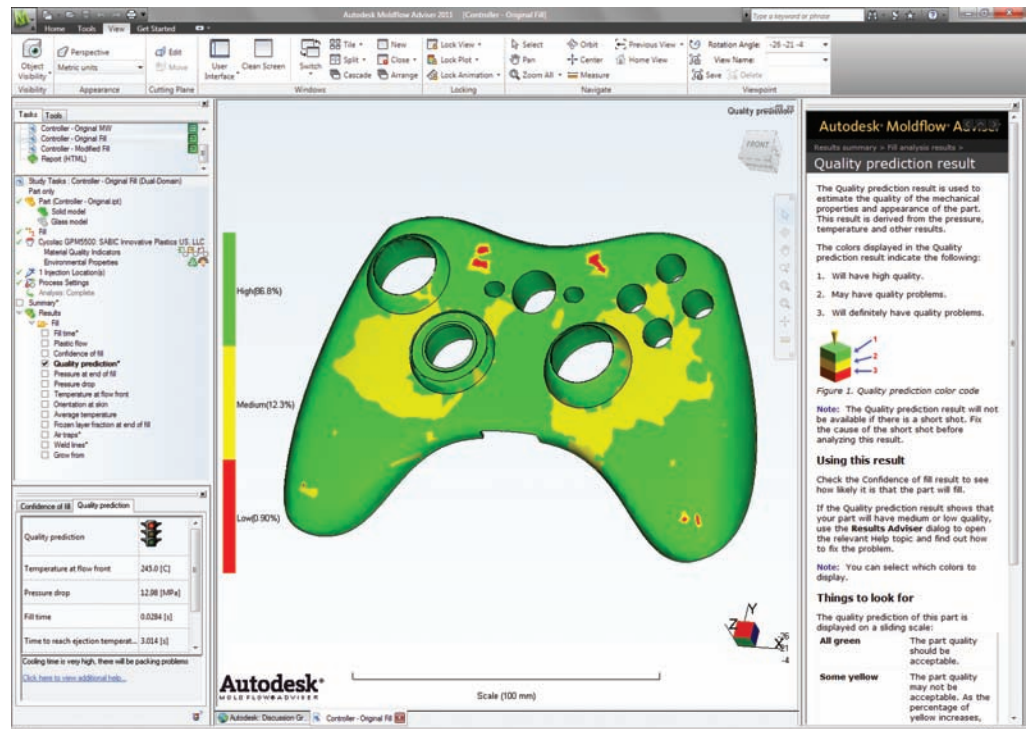

Simulation

Validate and optimize plastic parts and injection molds.

Plastic Flow Simulation

Simulate the flow of melted plastic to help optimize part and mold designs, reduce potential part defects, and improve the molding process.

Part Defects

Determine potential part defects, such as weld lines, air traps, and sink marks, and then rework designs to help avoid these problems.

Thermoplastic Filling

Simulate the filling phase of the thermoplastic injection molding process to help predict the flow of melted plastic and fill mold cavities uniformly; avoid short shots; and eliminate, minimize, or reposition weld lines and air traps.

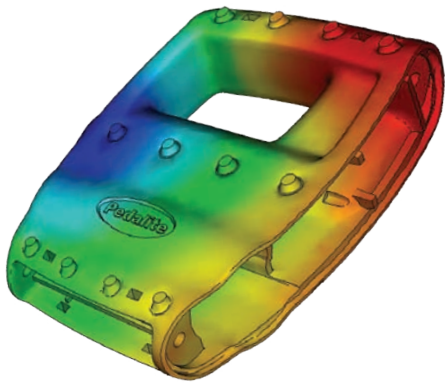

Thermoplastic Packing

Optimize packing profiles and visualize magnitude and distribution of volumetric shrinkage to help minimize part warpage and reduce defects, such as sink marks.

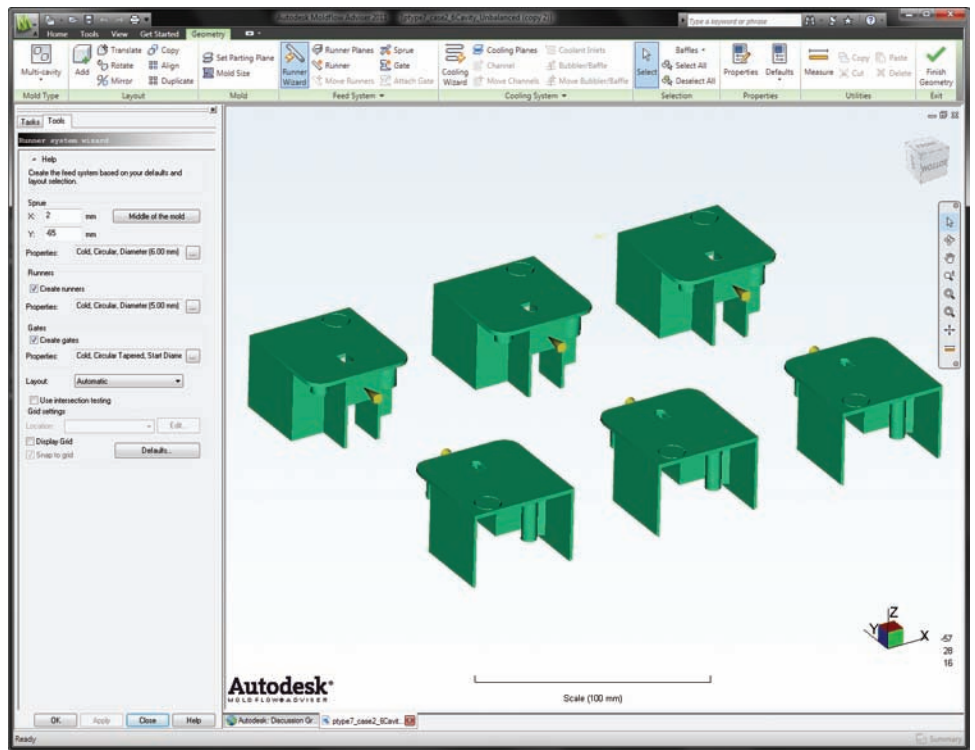

Feed System Simulation

Model and optimize hot and cold runner systems and gating configurations. Improve part surfaces, minimize part warpage, and reduce cycle times.

Gate Location

Identify up to 10 gate locations simultaneously. Minimize injection pressure and exclude specific areas when determining gate location.

Runner Design Wizard

Create feed systems based on inputs for layout, size, and type of components, such as sprue, runners, and gates.

Balancing Runners

Balance runner systems of single-cavity, multicavity, and family mold layouts so parts fill simultaneously, reducing stress levels and volume of material.

Hot Runner Systems

Model hot runner system components.

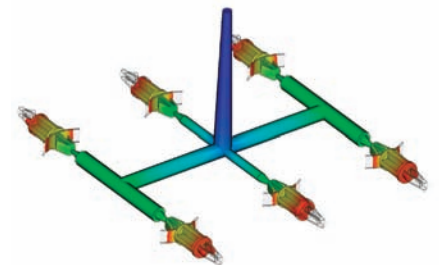

Simulation

Mold Cooling Simulation

Improve cooling system efficiency, minimize part warpage, achieve smooth surfaces, and reduce cycle times.

Cooling Component Modeling

Analyze the mold's cooling system efficiency. Model cooling circuits, baffles, and bubblers.

Cooling System Analysis

Optimize mold and cooling circuit designs to help achieve uniform part cooling, minimize cycle times, reduce part warpage, and decrease manufacturing costs.

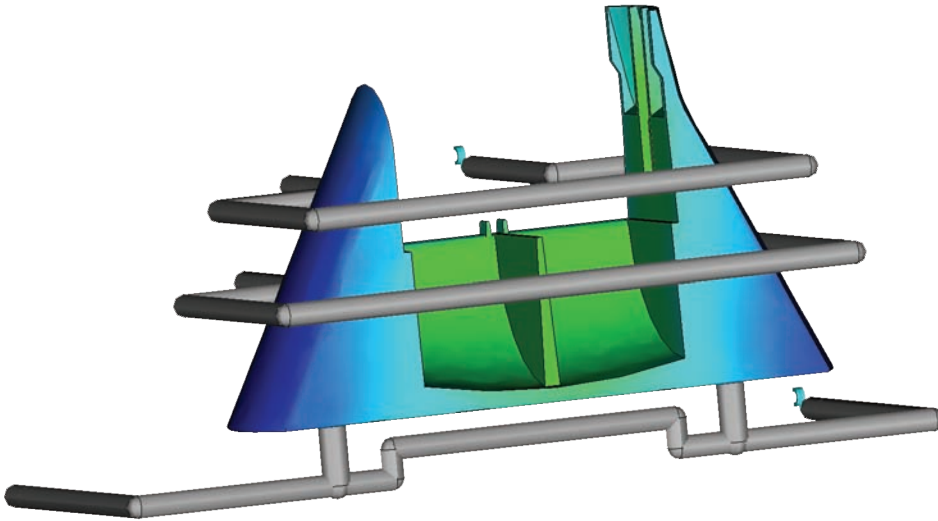

Shrinkage & Warpage Simulation

Evaluate part and mold designs to help control shrinkage and warpage.

Shrinkage

Meet part tolerances by predicting part shrinkage based on processing parameters and grade-specific material data.

Warpage

Predict warpage resulting from process-induced stresses. Identify where warpage might occur and optimize part and mold design, material choice, and processing parameters to help control part deformation.

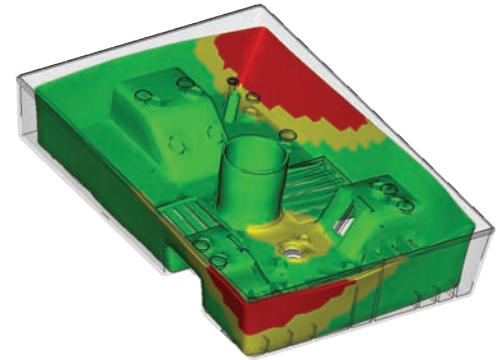

Fiber Orientation

Control fiber orientation within plastics to help reduce part shrinkage and warpage across the molded part.

CAE Data Exchange

Validate and optimize plastic part designs using tools to exchange data with structural simulation software. CAE data exchange is available with Autodesk® Algor® Simulation, ANSYS®, and Abaqus® structural simulation software to account for the effects of processing on the performance of fiber-filled, injection-molded plastic parts when subjected to service loading.

CAD Interoperability and Meshing

Use tools for native CAD model translation and optimization. Get geometry support for thin-walled parts and thick and solid applications. Select mesh type based on desired simulation accuracy and solution time.

CAD Solid Models

Import and mesh solid geometry from Parasolid®-based CAD systems, Autodesk® Inventor® software, CATIA® V5, Pro/ENGINEER®, and SolidWorks®, as well as IGES and STEP universal files.

Error Checking and Repair

Scan imported geometry and automatically fix defects that can occur when translating the model from CAD software.

Centerline Import/Export

Import and export feed system and cooling channel centerlines from and to CAD software to help decrease modeling time and avoid runner and cooling channel modeling errors.

Autodesk® Moldflow® CAD Doctor

Check, correct, heal, and simplify solid models imported from 3D CAD systems to prepare for simulation.

3D Simulations

Perform 3D simulations on complex geometry using a solid, tetrahedral, finite element mesh technique. Ideal for electrical connectors, thick structural components, and geometries with thickness variations.



Dual Domain Technology

Simulate solid models of thin-walled parts using Dual Domain™ technology. Work directly from 3D solid CAD models, leading to easier analysis of design iterations.

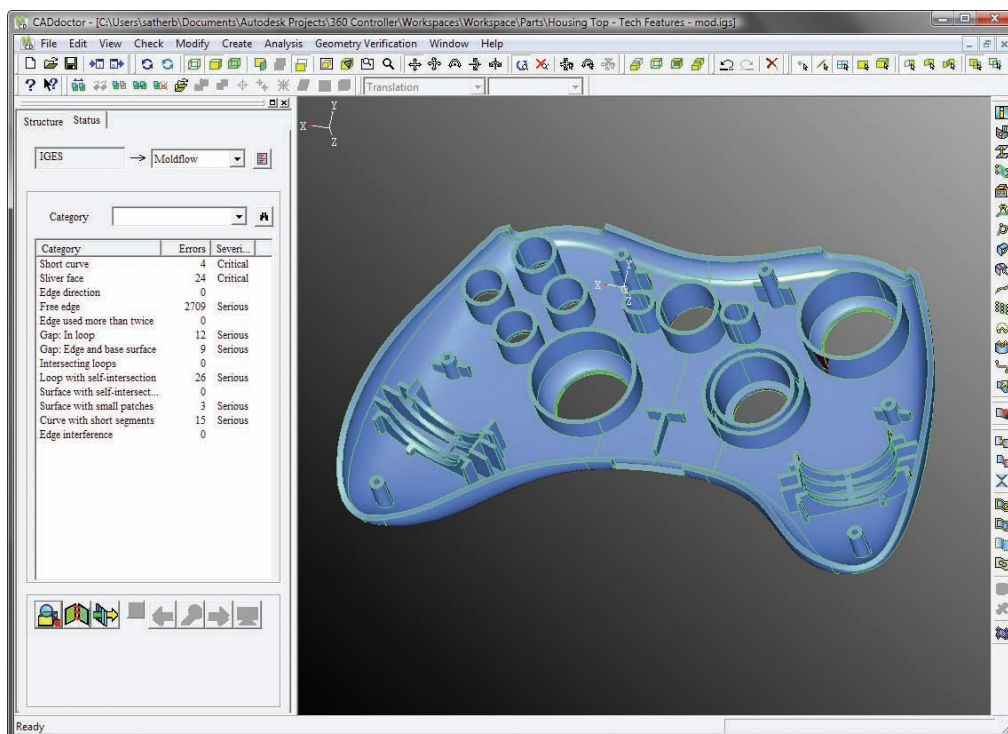
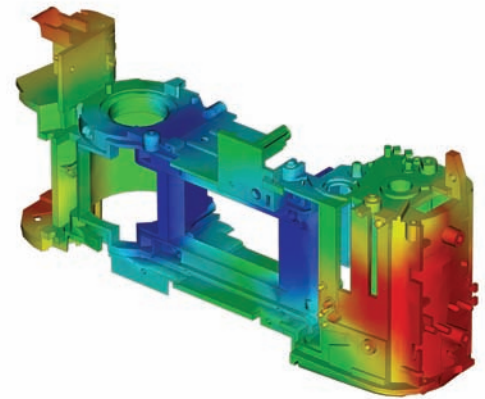

Results Evaluation and Productivity Tools

Visualize and evaluate simulation results, and use the automatic reporting tools to share the results with stakeholders. Take advantage of features such as a materials database and a cost adviser to further boost productivity.

Results Interpretation & Presentation

Use results-specific design advice to find a quick path from problem to solution and then document the solution.

Results Adviser

Query regions of a model to identify primary causes of short shots and poor part or cooling quality. Get suggestions on how to correct the part, mold, or process.



Automatic Reporting Tools

Use the Report Generation Wizard to create web-based reports. Prepare and share simulation results more quickly and easily with customers, vendors, and team members.

Microsoft® Office

Export results and images for use in Microsoft® Word reports and PowerPoint® presentations.

Autodesk® Moldflow® Communicator

Collaborate with manufacturing personnel, procurement engineers, suppliers, and external customers using Autodesk® Moldflow® Communicator software. The Autodesk Moldflow Communicator results viewer enables you to export results from Autodesk Moldflow software so stakeholders can more easily visualize, quantify, and compare simulation results.

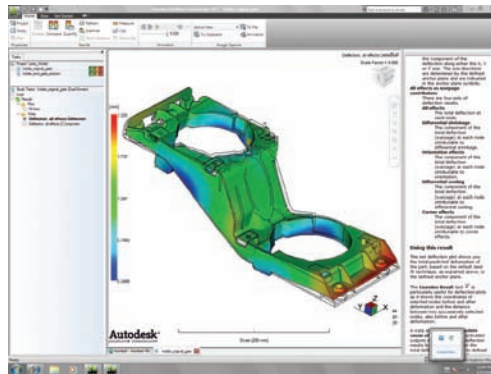

Material Data

Improve simulation accuracy with precise material data.

Materials Database

Use the built-in materials database of grade-specific information on more than 8,000 plastic materials characterized for use in plastic injection molding simulation.

Autodesk® Moldflow® Plastics Labs

Get state-of-the-art plastic material testing services, expert data-fitting services, and extensive material databases.

Productivity Tools

Use dynamic help and a cost adviser to boost productivity.

Dynamic Help

Get context-sensitive help on a results plot, including information on what to look for and how to correct typical problems. Learn more about solver theory, interpreting simulation results, and designing better plastic parts and injection molds.

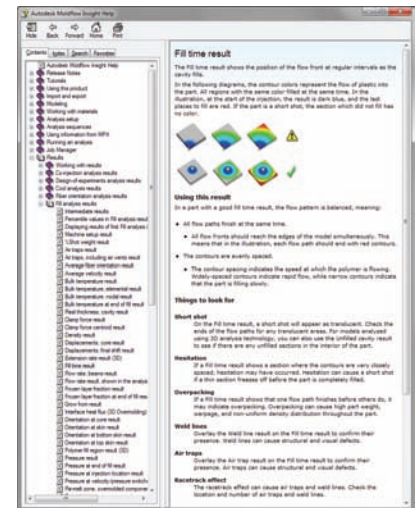

Cost Adviser

Learn what drives part costs in order to help minimize those costs. Estimate product costs based on material choice, cycle time, post-molding operations, and fixed costs.

